

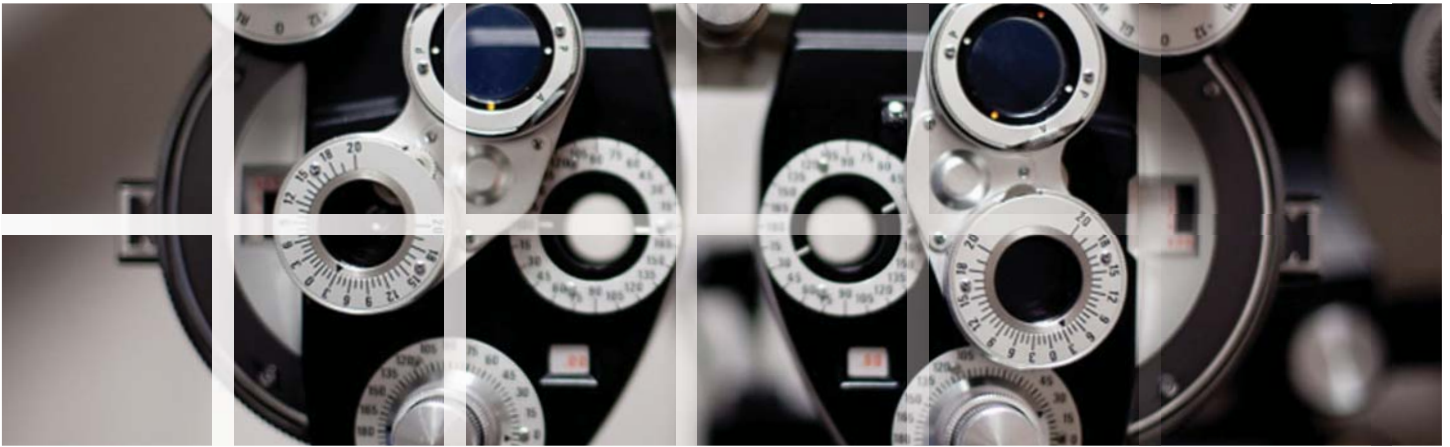

# Damages – Commercial Disputes



## Course Offerings:

### Commercial Damages 101

#### **A primer on commercial damages**

This course covers the various remedies typically sought in commercial litigation matters and how those remedies are determined. In particular, this course will address how lost profits and lost business value are determined, the various frameworks that are used to evaluate those remedies, and include a review of relevant case law.

### Financial Statements Overview

#### **Everything a litigator needs to know about financial statements**

This course offers a critical introduction to the different types of financial statements, details of those statements, and which elements are important for commercial damages quantification and why they are important. This course also addresses the various measures of profitability (regardless of whether they are reflected on a financial statement) and which ones are most relevant in determining lost profits or lost business value.

### Discovery

#### **What financial documents do you need and what do they reflect?**

Many lawyers are at a loss for determining what financial documents are relevant to each case, and once they receive financial information, what it means to them and their clients' claims. In this course, gain an understanding of the types of financial information that you should request in the discovery process, what the financial statements and financial information reflect, and how that information can be used in pre-case assessments, mediations, and litigation.

### Post Acquisition / Transaction Disputes

#### **An overview of post acquisition/transaction disputes as it relates to the economics and accounting of the deal**

Mergers and acquisitions, particularly in recent years, have led to disputes after the deals close primarily because of alleged breaches of representations and warranties, purchase price adjustments, earnout disputes, or accusations of pre-acquisition fraud. This course provides an overview of the economics and accounting analyses performed relative to these four main sources of post acquisition/transaction friction.

### Bankruptcy Preference and Avoidance Actions

#### **Effectiveness of common defenses to bankruptcy preference claims**

Evaluating the effectiveness of common defenses to bankruptcy preference claims is often enhanced with the involvement of a financial expert. In this course, SRR professionals assist counsel in understanding the measurement of Ordinary in the Industry, Ordinary Between the Parties and New Value. Our discussion will include a review of relevant cases, common research sources, information requested from clients and common calculations and analysis.

# Damages – Intellectual Property

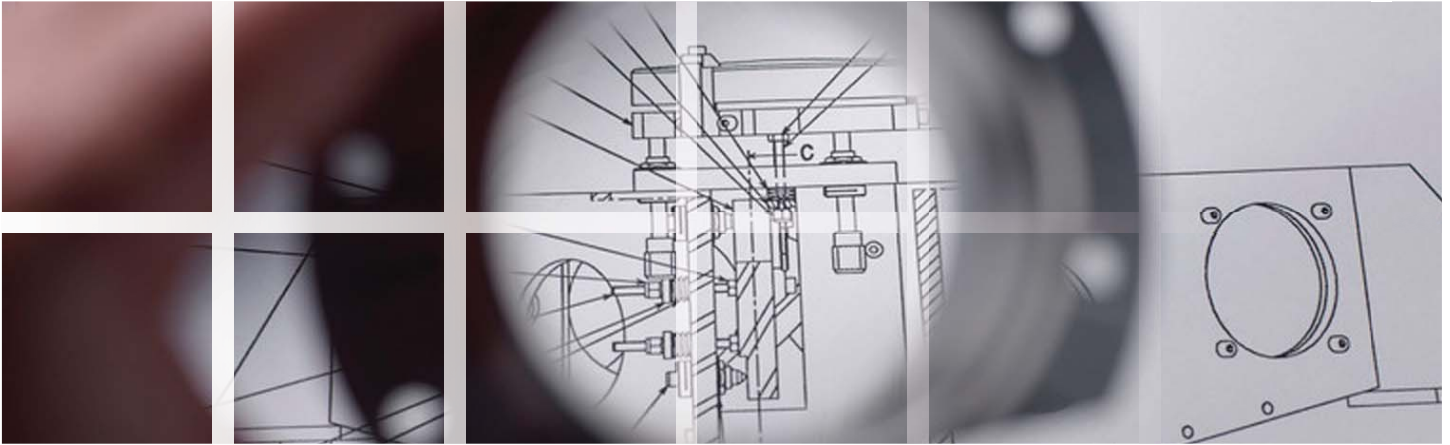

## Course Offerings:

### Patent Damages 101

#### **A primer on patent damages**

This course covers the various remedies typically sought in patent infringement matters. In particular, this course will address how lost profits and reasonable royalties are determined, the various frameworks that are used to evaluate those remedies, and include a review of relevant case law.

### Recent Case Law Overview

#### **A look at recent cases affecting damages quantification**

This course addresses recent Federal Circuit and district court decisions such as *Siemens v. Saint-Gobain*; *Uniloc v. Microsoft*; *Finjan v. Secure Computing*; *Wordtech v. Integrated Network Solutions*; *Lucent v. Microsoft*; *ResQNet v. Lansa*; *Cornell v. Hewlett-Packard*; *Tyco Healthcare v. E-Z-EM*; *i4i v. Microsoft*; *IP Innovations v. Red Hat*; and others with a particular focus on how those decisions impact the quantification of IP damages.

### Understanding IP Damages Discovery

#### **What your damages expert will rely upon and why**

This course addresses the documents and information necessary to support a damages calculation. We will address the different sources of information, such as standard business records typically used by damages experts. This knowledge will ensure that the legal team and the expert are on the same page. It will also better equip counsel to address discovery disputes and address documents during examinations.

### Understanding Apportionment and the Entire Market Value Rule

#### **A review of the apportionment concept and the Entire Market Value Rule and their application in patent damages**

Judge Rader's decision to strike the plaintiff's expert report in *IP Innovation v. Red Hat* emphasizes the need to understand and correctly apply the EMVR. This course takes a historical look at the development of the apportionment concept and the EMVR in relevant case law and explains the economic basis underlying these concepts.

### Royalty Audits

#### **Auditing self-reporting agreements**

Royalty audits almost always identify underreported royalties. However, there are many benefits beyond recovery of any underpaid royalties. This course explains, in simple and straight forward terms, those benefits as well as what to expect in a royalty audit, common findings from those audits, and recommendations when entering into new self-reporting agreements.

# Valuation



## Course Offerings:

### How to Review a Valuation Report

#### Understanding the critical elements of a valuation report

When reviewing a business valuation report, which assumptions, methodologies, underlying data, etc. should be critically examined by an attorney? This course will provide instruction on how to assess the quality and reliability of valuation analyses. In addition, the course will provide tips on how to most efficiently review a report to understand the key components leading to the conclusion of value.

### Valuation Issues in Bankruptcy

#### Understanding the key elements of valuation to consider during bankruptcies

This course summarizes areas where valuation issues are relevant throughout a bankruptcy, including adequate protection, claims determination, plan confirmation, and asset recovery issues. It also addresses valuation issues specific to distressed companies and summarizes concepts through examples and court decisions.

### How to Review a Commercial Real Estate Appraisal Report

#### Understanding the critical elements of a real estate appraisal report

When reviewing a commercial real estate appraisal report, which assumptions, methodologies, and underlying data should be critically examined? By presenting key questions to ask of the appraiser, this course will provide a guide on how to assess the quality and reliability of commercial real estate appraisals.

### Business Valuation

#### A Primer for the Legal Professional

Business valuation issues arise in many situations in which attorneys are involved. The goal of this course is not to teach attorneys how to value a business themselves, but rather to arm them with enough information to be able to:

- ■ Understand the context of a valuation and the basics of the underlying theories and approaches;
- ■ Ask well-thought out questions regarding the valuation analysis during the attorney's review of work;
- ■ Challenge the assumptions and play devil's advocate with respect to the work;
- ■ Confirm that the assumptions and premise on which the valuation is based are not inconsistent with the law or legal arguments on the case; and
- ■ Design questions to ask the valuation expert for purposes of direct testimony or cross examination

# Forensic Accounting



## Course Offerings:

### Accounting 101 for Attorneys

#### Accounting basics

The ability for counsel to understand the basics of accounting is essential in formulating strategic and technical objectives in all types of matters. In this course, you will learn about the essential components of accounting, including key accounting areas of concern and changes in accounting standards that may affect your clients or company.

### Internal Investigations

#### How to protect your clients and company

This course will assist you in developing techniques and tools to use in every phase of the investigative process. The course will expand on key considerations at the outset of an investigation, the processes and procedures used during the investigation, common issues or roadblocks in conducting the investigation, dealing with regulatory and audit firm participation in the investigation, and items to consider in concluding the investigation.

### Current Fraud Trends and Investigations

#### A look at recent trends impacting fraud

Stock options backdating, revenue recognition, ponzi schemes, and other issues that companies face in internal investigations are constantly changing. This course discusses current fraud trends and areas that companies should be on the lookout for in future dealings with fraud and employee misconduct.

### Bribery & Corruption

#### What does the changing regulatory environment mean to you?

With the recent aggressive enforcement of the Foreign Corrupt Practices Act and the passage of the U.K. Bribery Act, companies will be required to reevaluate and enhance their anti-corruption compliance programs to comply with stricter global laws and increased enforcement. This course lays the groundwork for the issues that companies will need to address, provide practical steps to developing and enhancing an adequate compliance program, and provide tips and tools to use in monitoring a company's activities, both in normal operations and in due diligence related to mergers and acquisitions.

### Trust Disputes

#### When the trusted advisor breaches his/her fiduciary duty

Knowing how and when to rely on the expertise of a forensic accountant can be the difference between recovering misappropriated assets and never knowing they were gone in the first place. This course will inform participants on how to use, and what is expected from, a forensic accountant in a trust dispute.

# E-Discovery / Computer Forensics

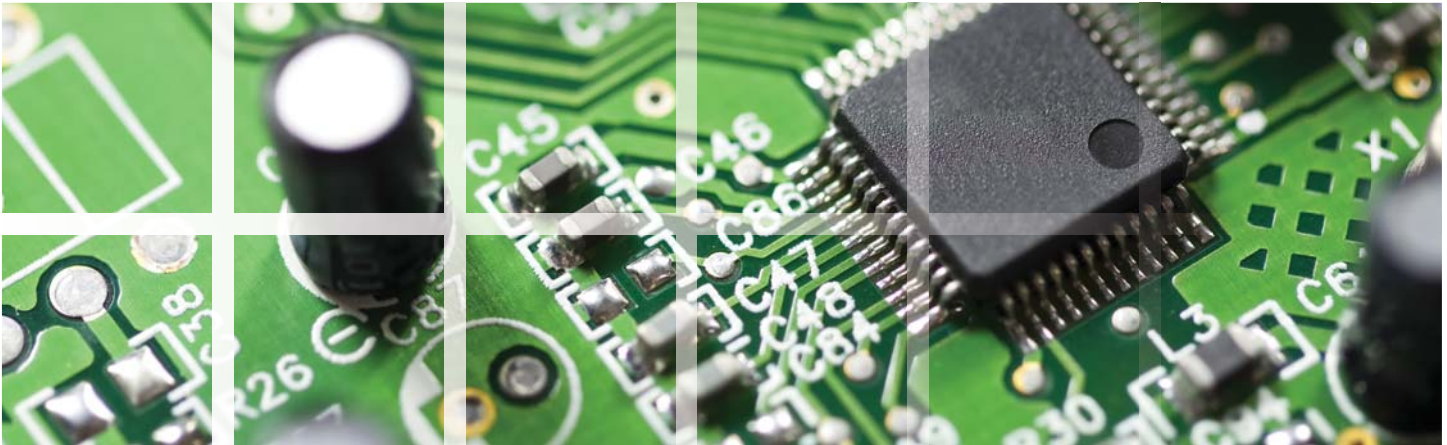

## Course Offerings:

### E-Discovery before the Securities and Exchange Commission and the Department of Justice

#### **Production to the government in response to a subpoena**

The task of an E-Discovery response to a government subpoena can be overwhelming and expensive. This course explains the processes, procedures, and some of the available tools to manage an efficient, cost effective production to the government.

### Computer Forensics in Labor & Employment Disputes

#### **Using computer forensics in labor & employment disputes**

This course describes the computer forensic techniques used to investigate theft of intellectual property, non-compete, harassment, and other employment issues. In addition, this course will provide an overview of the types of information recoverable using the previously discussed technologies.

### Cross Border E-Discovery

#### **Collection efforts outside the United States**

With the increase of FCPA and antitrust investigations by the government, US-based companies are looking for efficient ways to collect, review, and produce electronically stored information from their non-US entities. This course describes how to avoid large travel expense and to promote the use of remote collection tools.

### Controlling Costs in E-Discovery

#### **Red flags and road blocks**

E-Discovery costs can be overwhelming and expensive. This course outlines some of the potential problem areas in E-Discovery that can lead to increased costs. In addition, this session will describe some of the preemptive efforts a company can take to avoid these problem areas.

### Litigation Readiness

#### **Preparing for the inevitable E-Discovery effort in litigation**

The continuing explosive growth of electronically-stored information, combined with the now established requirements for electronic discovery, have caused increasing focus to be placed on mechanisms by which companies can address E-discovery. In this course we will discuss how, through proactive planning, companies can decrease the business interruption and expense of complying with E-Discovery requirements through litigation.

Stout Risius Ross (SRR) is a premier financial advisory firm that specializes in Investment Banking, Valuation & Financial Opinions, and Dispute Advisory & Forensic Services.

We serve a range of clients from Fortune 500 corporations to privately held companies in numerous industries around the world. Our clients and their advisors rely on our premier expertise, deep industry knowledge, and unparalleled responsiveness.



<u>Los Angeles</u>	<u>Chicago</u>	<u>Atlanta</u>	<u>Detroit</u>	<u>Cleveland</u>	<u>Washington D.C.</u>	<u>New York City</u>
+1.310.775.2510	+1.312.857.9000	+1.404.369.1110	+1.248.208.8800	+1.216.685.5000	+1.703.637.3700	+1.212.400.7299



INVESTMENT BANKING

VALUATION & FINANCIAL OPINIONS

DISPUTE ADVISORY & FORENSIC SERVICES